



TEACHER'S MANUAL:

MANUFACTURE OF PUSH BUTTONS BY 3D PRINTING

COORDINATOR:

BEATRIZ F. NÚÑEZ ANGULO

AUTHORS:

WILCO H.M. VERBEETEN
MIRIAM LORENZO-BAÑUELOS
ROSA M^a SANTAMARÍA CONDE



Co-funded by the
Erasmus+ Programme
of the European Union



UNIVERSIDAD
DE BURGOS

Disclaimer

This project has been funded with support from the European Commission. This publication reflects the views only of the author, and the Commission cannot be held responsible for any use which may be made of the information contained therein.



INDEX

<u>INTRODUCTION</u>	5
<u>METHODOLOGY</u>	6
<u>DATA SHEETS</u>	7
Data sheet I	8
Data sheet II	15
Data sheet III	22
<u>3D PRINTER</u>	35
3D printer pieces	35
3D printing materials	37
Steps in 3D printing	37

INTRODUCTION

Educational technology plays a key role in the teaching-learning process, however, the absence of mechanisms adapted to people with disabilities can be an obstacle to the use of technological resources, generating inequality and limited autonomy. To cover these inequalities, assistive technologies have been created in order to guarantee access to them.

This manual is created for the teacher to learn how to design and create personalised push buttons using 3D printing.

As time goes on, there are more and more 3D printers with better technology, and at a cheaper price; moreover, the knowledge required for their proper and safe usage is closer to everyone than ever. This manufacturing system, which might seem more typical of engineering, is being transferred to the educational field in order to provide technical solutions for students with special educational needs.

This manual will explain the most important basic steps that allow a teacher to manufacture a push button that facilitates the usage of the computer for students with motor disabilities in the upper limbs, but with preserved intelligence, betting for their inclusion in the educational environment. This push button will allow control of the computer pointer, moving it up, down, left, right, and allowing 'clicking' like a traditional mouse.

The manual is structured in three sections. The first of these refers to the methodology followed in the manufacturing process of the pushbuttons, from the generation of the primitive idea to the printing of the parts and the assembly of the pushbuttons. Next, the technical data sheets of two pushbuttons made using different procedures are presented; firstly, one developed from digital design using the V5R20 programme, and secondly, one developed using 3D scanning of a mould (photogrammetry). Finally, a tour of the parts of a 3D printer, the types of materials it uses, and the steps to print a part.

It is expected that the application of the manual will allow the development and creation of push buttons, responding to the needs and characteristics of the learners.

METHODOLOGY

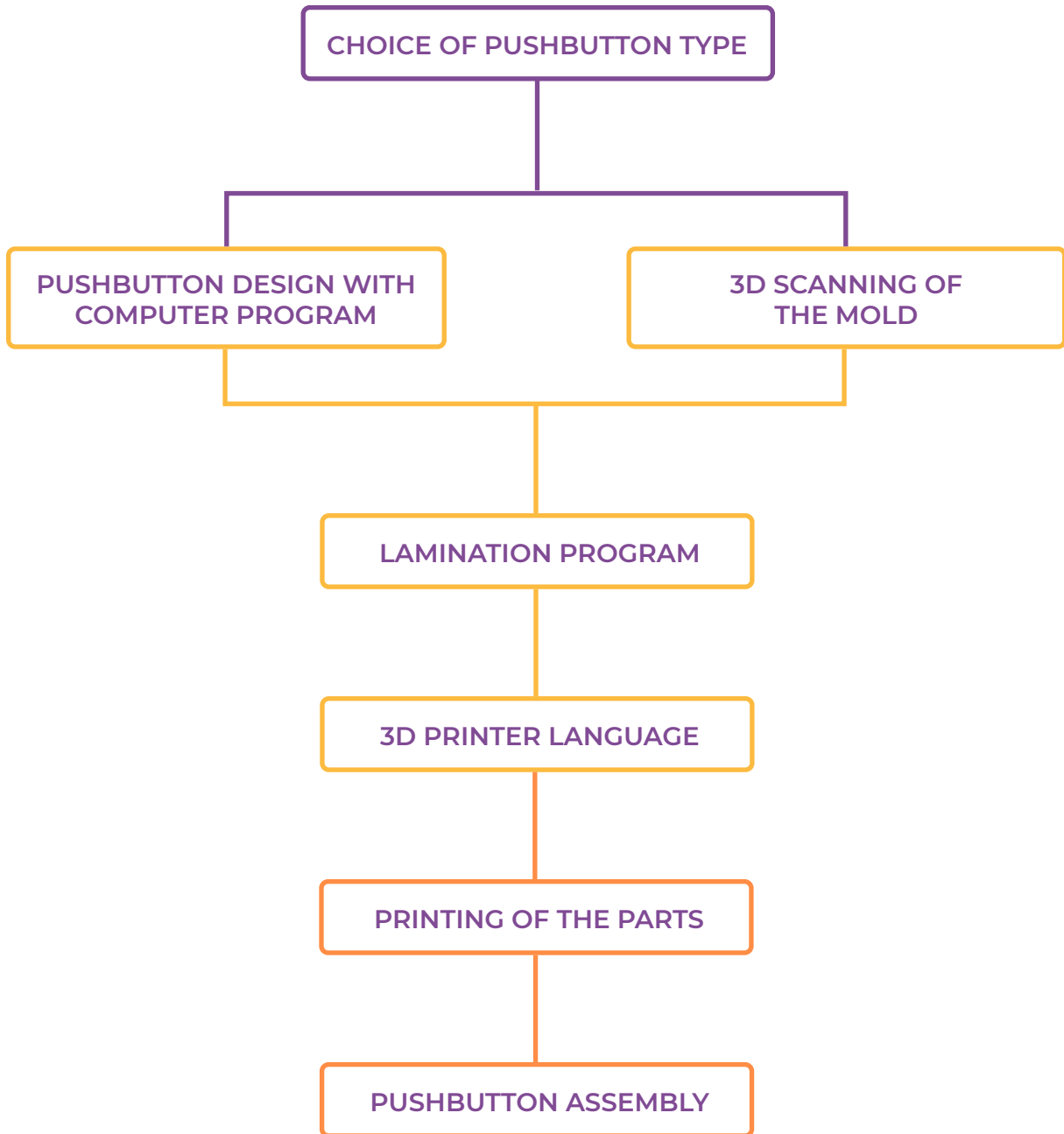

The methodology to be followed starts with the choice of the type of push button according to the needs required by students with motor disabilities. Then we will proceed to its design through computer programs such as CAD, and in the case that the push button needs a specific shape (e.g. the student's fist), we will scan a mold made from another malleable material, using photogrammetry. Finally, we will manufacture the push button by 3D printing it.

In our case, the manufacturing method of the pushbuttons will be the extrusion of a molten filament. The operation is simple, the printer will create the parts by heating and extruding the plastic filament layer by layer in ascending order.

DATA SHEETS

Next, we will proceed to the presentation of three adapted pushbuttons made by 3D printing; two of them developed and designed from computer programs, and the other one from the 3D scanner technique by photogrammetry.

The following tables show aspects such as: the purpose of the pushbutton, the materials and tools used in its elaboration, and its step-by-step development. In order to improve the understanding of the manual, all the information is accompanied by images and links to videos that illustrate each section in a useful and complete way.



Pushbutton designed with computer program (Catia V5R20).



Pushbutton made by 3D scanning of a mold (photogrammetry).

DATA SHEET I: PUSHBUTTON DESIGNED AND DEVELOPED FROM A COMPUTER PROGRAM

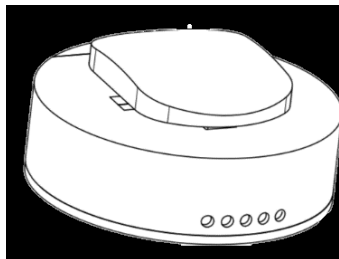

AIM:

Design and manufacture of an ergonomic and personalized push button through 3D printing, which functions as a mouse in the use and management of a computer. It takes into account the low cost so that families and schools with limited resources can take advantage of it.

TARGET:

Students with special educational needs (motor disability in upper limbs and preserved intelligence).

PUSHBUTTON FUNCTIONS:

Up, down, left and right pointer movement. In addition, it allows you to 'click' like a traditional mouse.

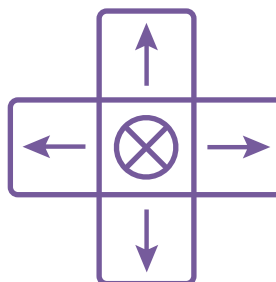

MATERIAL:

The materials and tools presented below are available at any hardware shop, online hardware store, or electric shop.



8 Micro key switches



Multiconductor cable 2 metres



Tin



Contact Glue



Pliers

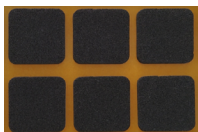

4 Non-slip adhesive rubbers



5 Male jack connectors 3'5mm



4 Screws M2 10mm



Tin Solder



Scissors



Screwdriver

To connect the push button to a computer or tablet via USB, an adapter can be used. For example the USB adapter “enCore”. This USB adapter is responsible for sending the commands to move the cursor from the computer. It is compatible with Windows, Mac, Linux or Andriod operating systems.



STEPS TO FOLLOW:

1. Printing of the pieces

For the printing of the parts, the printing parameters must be configured according to the 3D printer and the material used for it. What is recommended is the position in which they should be printed to avoid a worse finish, a bad orientation of the fibres which can mean a loss of resistance and an unnecessary waste of material.

If a customised grip is required, only the joystick shaft will be printed and the scanned grip model separately. Once printed, the grip is attached to the joystick with strong glue.

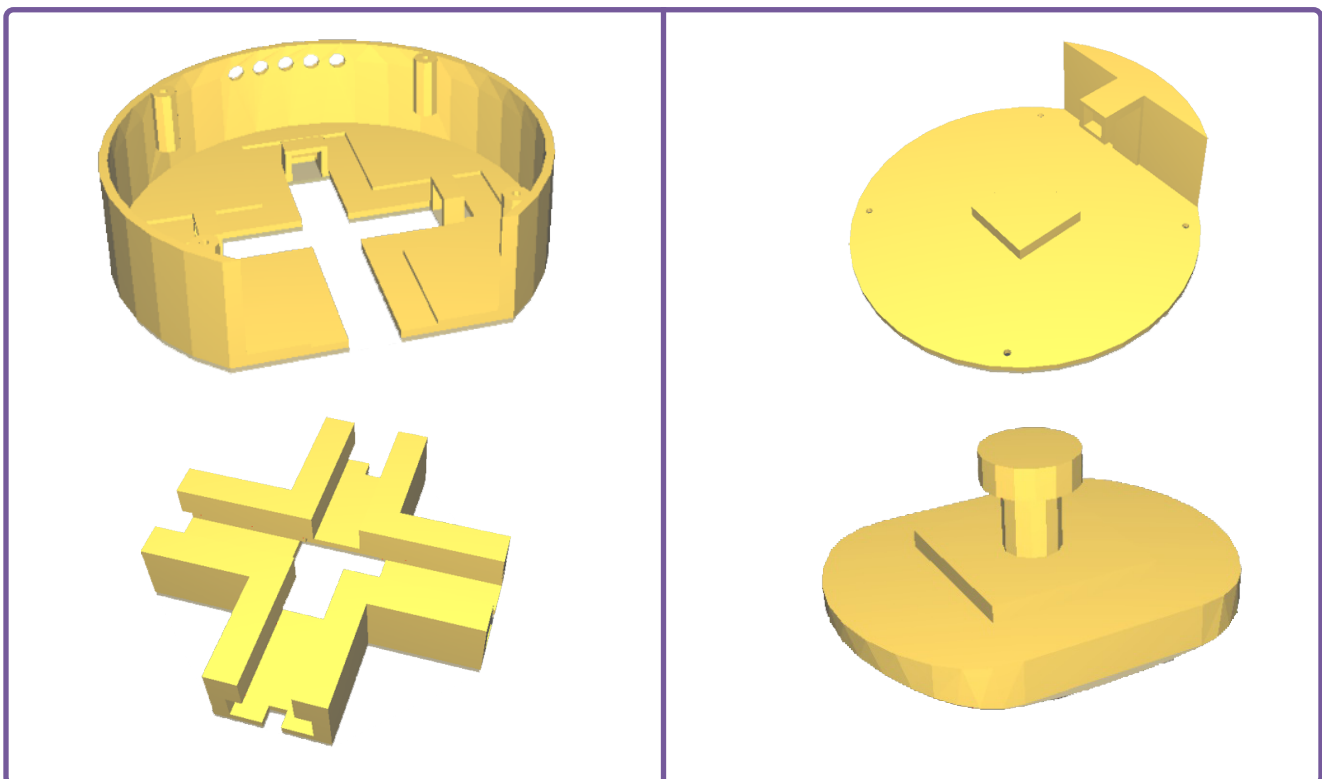

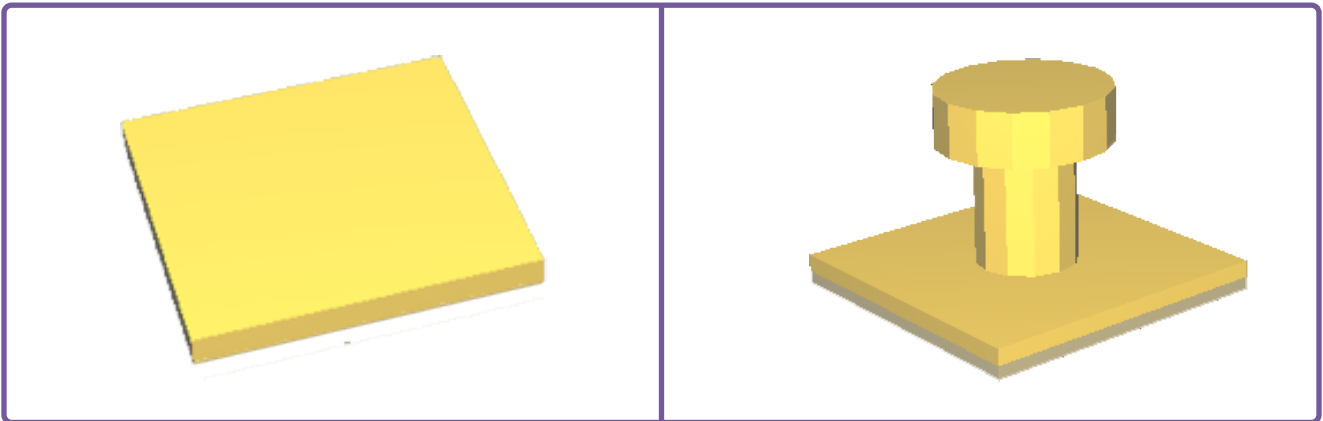

Once all the parts have been printed, the pushbutton is assembled:

1. Check that all parts fit together before fastening.
2. If any parts do not fit, sand until they fit perfectly.
3. Solder the micro switch with the cable. To do this, the cable must first be stripped with scissors.



4. Place the micro switches in the holes in the base by first passing the cable through and fix them with strong glue.

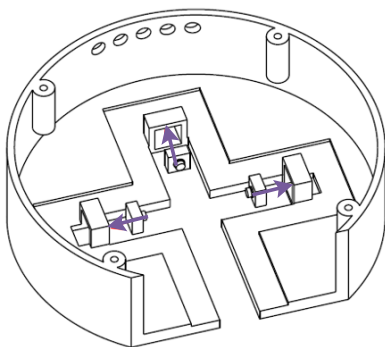

5. Fit the rails into the rails of the base and then insert the joystick.

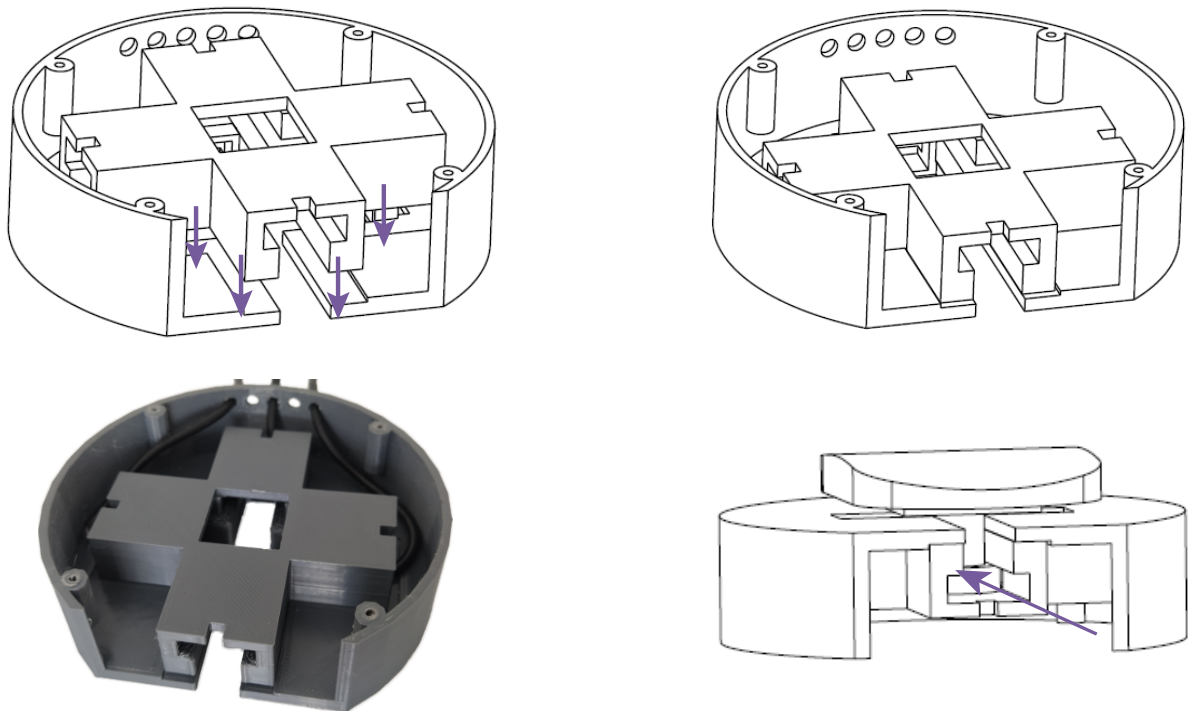

6. Glue 4 microswitches to the square part of the cover and 1 microswitch in the hole of the rail extension, soldering them to a wire as in 'step 3'.

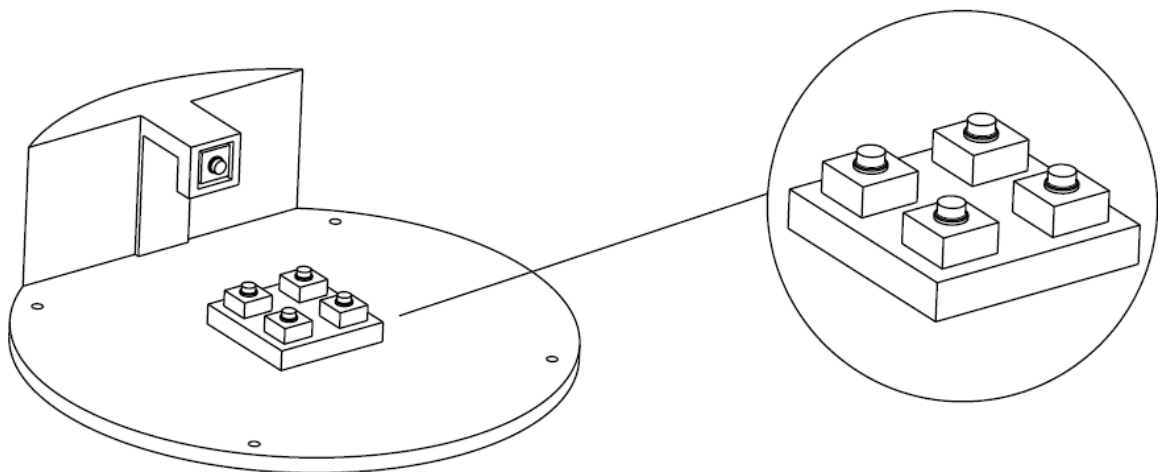

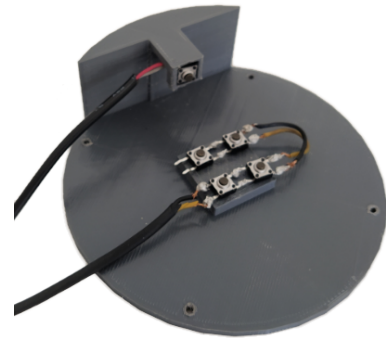
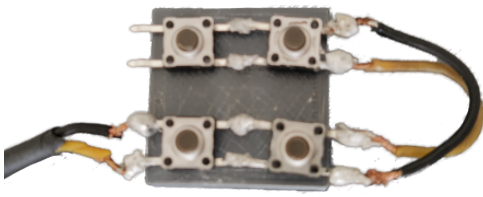

7. Place the 3 mm thick plate on top of the 4 microswitches making sure that the base with the rails and the joystick are in the correct position. Do not forget to pass the 2 cables coming out of the cover through the 2 remaining holes in the base.

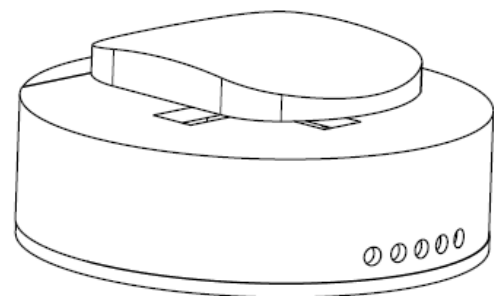
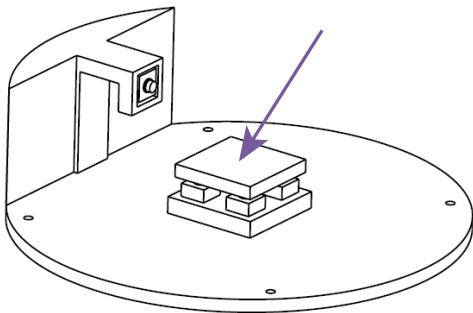

8. Screw the cover onto the base with the screwdriver.

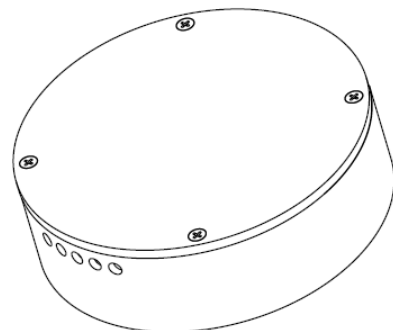
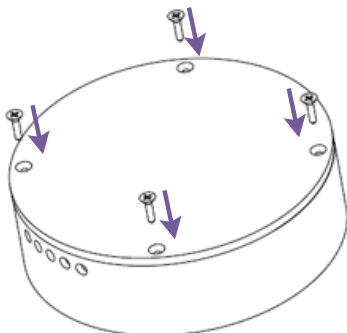



9. Solder the 5 male jacks to the 5 wires coming out of the pushbutton using the pliers on the tab shown in the picture to prevent them from coming loose.



10. Glue 4 anti-slip stickers on the lid over the screws so that they are not visible and to prevent scratching and slipping on the surface to be supported.

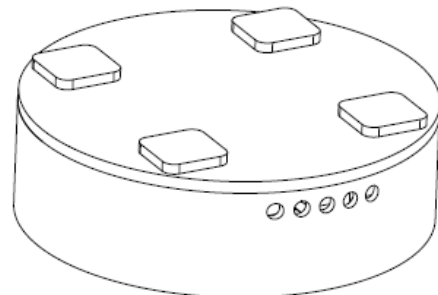
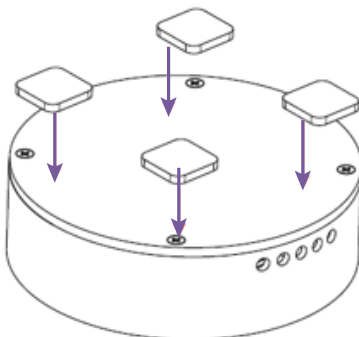

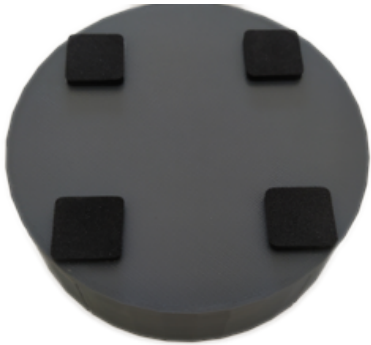

11. Connect the pushbutton to the enCore USB adapter and the USB adapter to the computer.

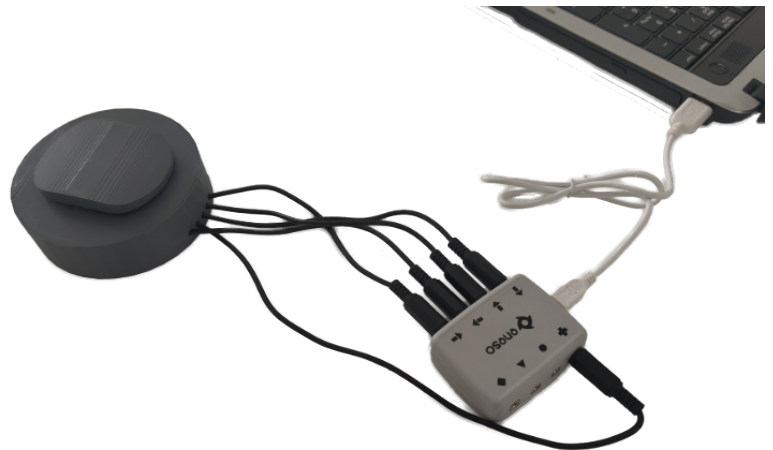

DATA SHEET II: PUSHBUTTON PRODUCED BY PHOTOGRAMMETRIC 3D PRINTING USING AUTODESK RECAP.

Photogrammetry is the technology that makes it possible to generate realistic textured 3D models using photographs of the same object.

The particularity of this technology is its usefulness as it can be used by anyone with a mobile phone or a computer because it does not require specialised tools. What it does require is powerful hardware because most photogrammetry programmes require the computer to have enough capacity to process the images and generate the digitised 3D model.

Photogrammetry is one of the simplest methods of 3D scanning. It has many advantages over other technologies, mainly its zero cost.

On the limitations, it needs high quality reference images to provide good results. And the more pictures you have, the better the result. Although the scanning speed is high, with many photos the running time of the algorithm is also high.

The scanning process for the photo-based conversion of an object into a textured 3D model will be explained using the **Autodesk ReCap program**: <https://www.autodesk.es/products/recap/>

This programme can be tested free of charge for 1 year by means of an educational licence for non-profit cases.



AIM:

Design and manufacture of an ergonomic and personalized push button through 3D printing, which functions as a mouse in the use and management of a computer. It takes into account the low cost so that families and schools with limited resources can take advantage of it.

TARGET:

students with special educational needs (motor disability in upper limbs and preserved intelligence).

STEPS TO FOLLOW:

1. Take 100 photos (mobile phone or camera) evenly distributed in three positions around the mould:
 - Profile (side).
 - Inclined at 45°.
 - Plant (from above).

- Open Autodesk ReCap software and select **new project** followed by **photo to 3D**.

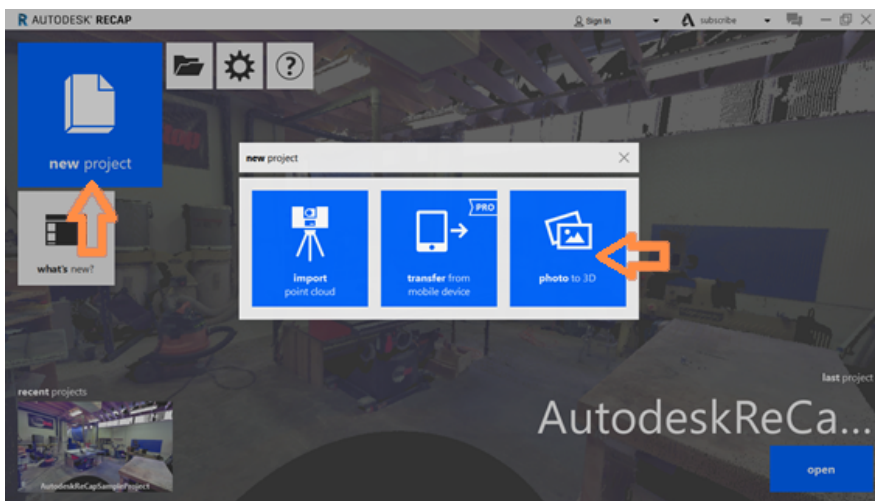

- ReCap Photo will open, register with the user account and add the photos taken by selecting **Object**. Once the photos have been imported select **Create**.

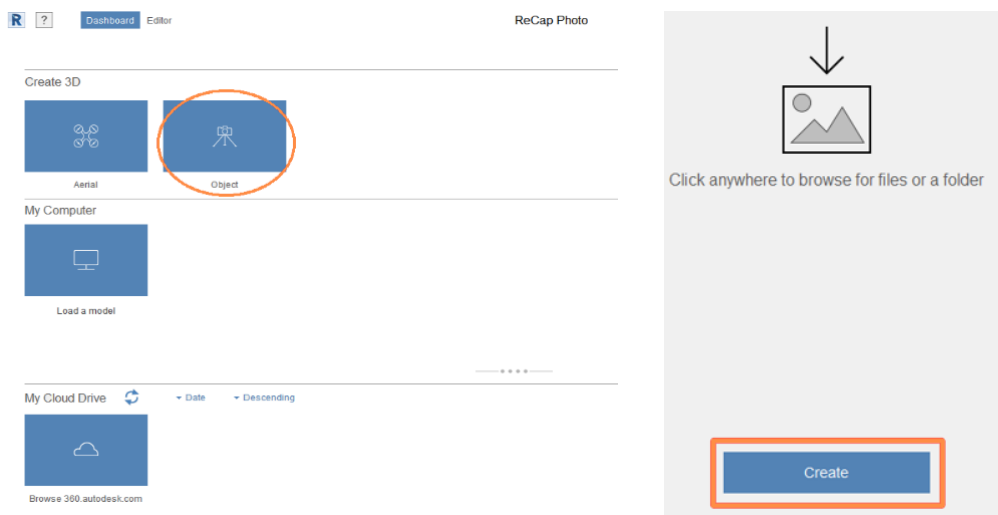

- Pressing **Start** starts the processing of the photos, which can take quite a long time (2-3 hours).



- Once the 3D model has been processed, it appears in **My Cloud Drive** and will be downloaded to the computer by selecting the arrow in the bottom right corner.

Once downloaded, the 3D model is displayed in **My Computer** where the file can be opened for editing.

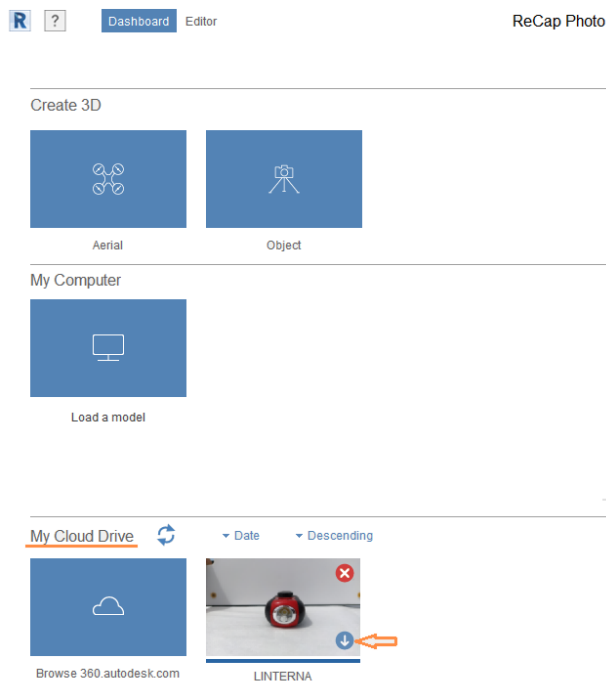

- The 3D model is loaded into the editor where there are several tools on the left and bottom to modify it.



- Select the left hand tool **Slice & fill** to remove a cutting plane that does not belong to the mould and depending on whether you want the mould to be hollow or filled select **No fill** and **Fill** respectively.

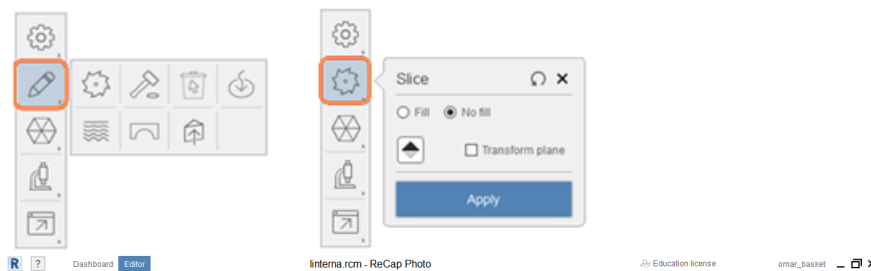

- To remove excess elements precisely, you can use the tool at the bottom, which contains a square figure. Select the unwanted parts and press the delete key.

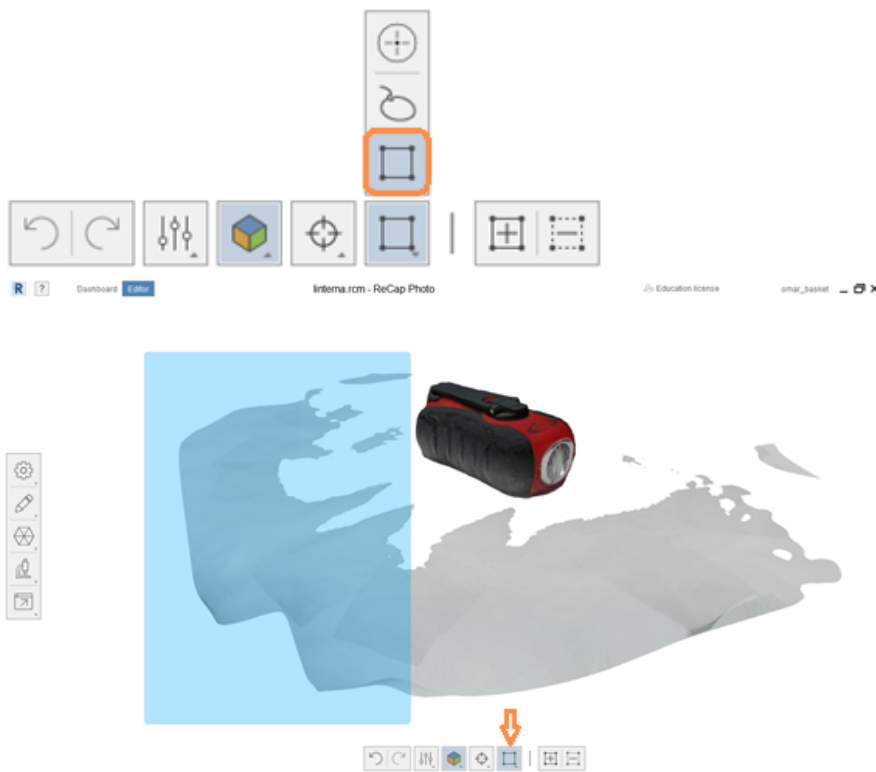

- The measurements of the model are set in mm using the **Scale & units** tool by selecting two reference points on the model. The measurement is entered in **Distance**.

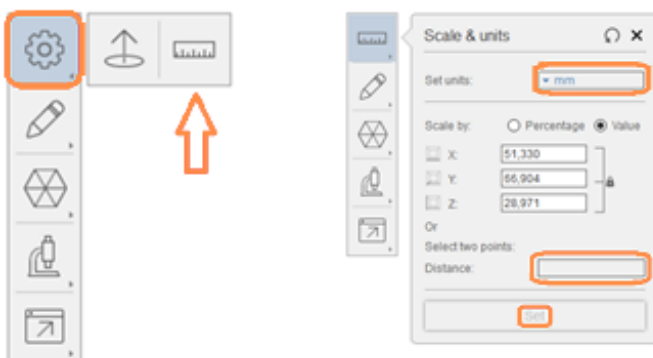

10. Optimisation of the 3D model to facilitate printing with the **Decimate mesh** tool. A percentage of 70% is recommended but may vary depending on the model used. Click on **Decimate all** to optimise.

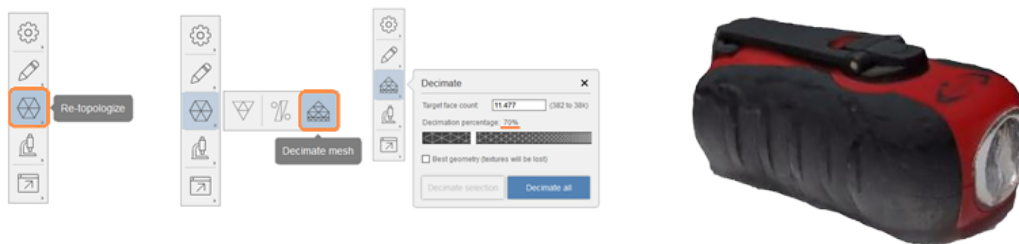

11. Finally, export the model as an STL file from the **Export model** option, so that it can be opened in the laminator program where the printing parameters will be configured.

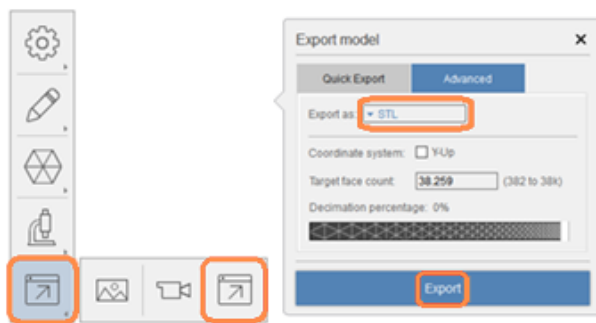

DATA SHEET III: INSTALLATION INSTRUCTIONS FOR A PUSHBUTTON.



AIM:

Design and manufacture of an ergonomic and personalized push button through 3D printing, which functions as a mouse in the use and management of a computer. It takes into account the low cost so that families and schools with limited resources can take advantage of it.

TARGET:

Students with special educational needs (motor disability in upper limbs and preserved intelligence).

PUSHBUTTON FUNCTIONS:

Up, down, left and right pointer movement. In addition, it allows you to 'click' like a traditional mouse.

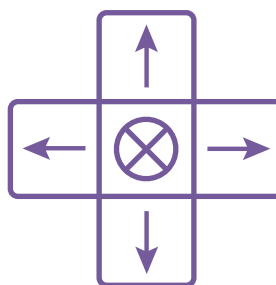

MATERIAL:

The materials and tools presented below can be obtained in any hardware shop, online store, or electronics shop.

To access the video showing the materials and tools required, click on the following link:

https://www.youtube.com/watch?v=N59x29f34vI&ab_channel=Rub%C3%A9nS%C3%A1enz



8 Micro key switches



5 Wires de 1 metro



4 Screws M3 16mm



Tin



Contact glue



5 Male jack connectors 3'5mm



1 Screw M3 30mm



4 Screws M3 12mm



Tin Soldering



Silicone gun

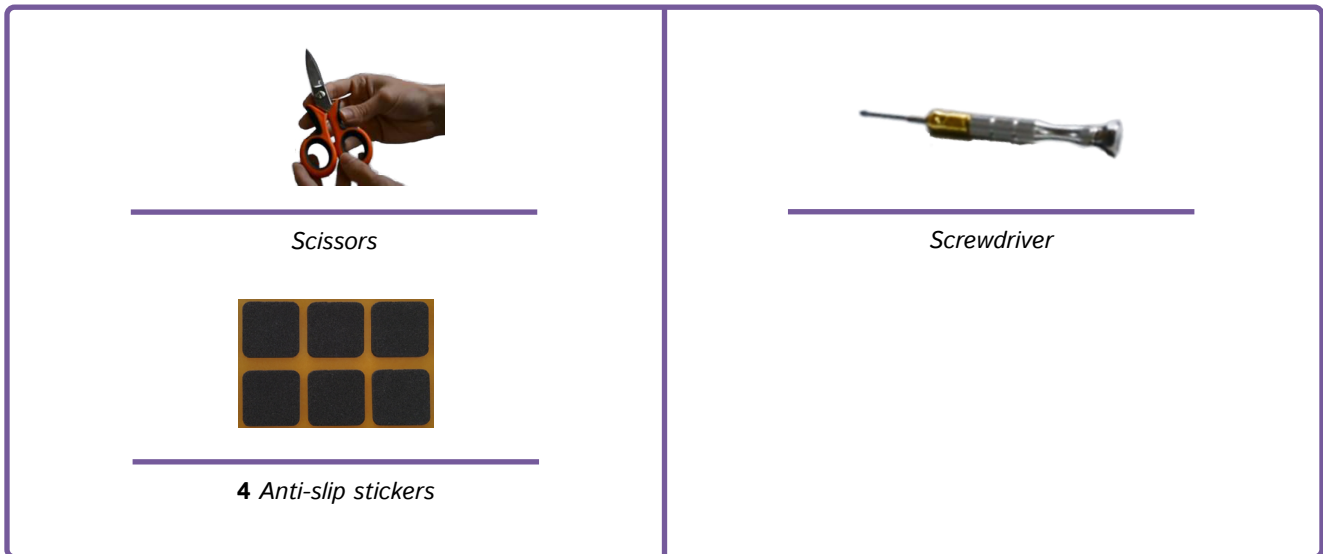

STEPS TO FOLLOW:

1. Printing of the pieces

For the printing of the parts, the printing parameters must be configured according to the 3D printer and the material used for it. What is recommended is the position in which they should be printed to avoid a worse finish, a bad orientation of the fibres, which can mean a loss of resistance and an unnecessary waste of material.

For the printing of the joystick, the shaft and the head will be printed separately, this is due to the capacity of interchanging one head for another, thus favouring a greater degree of personalisation of the pushbutton.

Note that all the designs of the printed pieces are available on Thingiverse:

<https://www.thingiverse.com/>



Top cover

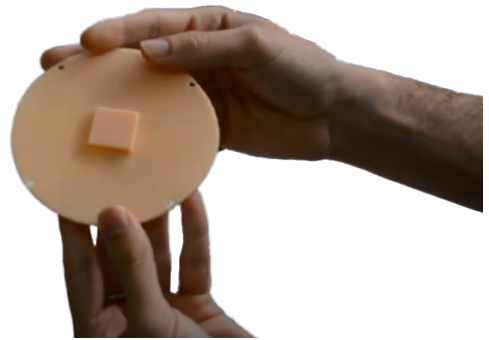

Bottom cover



Guidance or lane

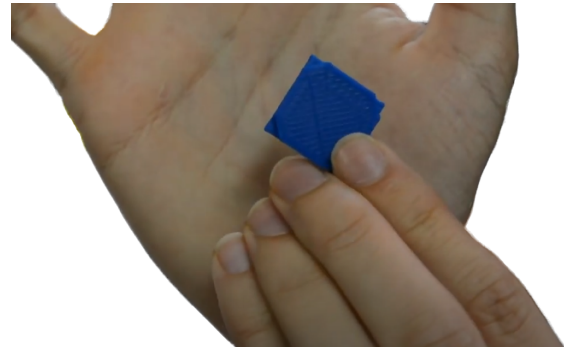

Small plate



Joystick axis

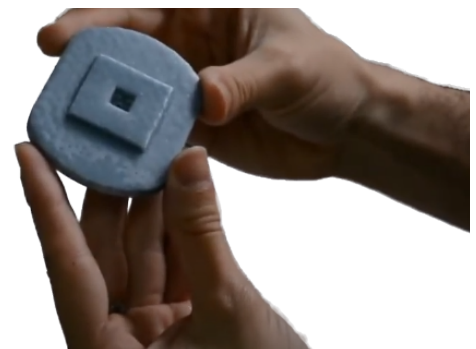

Generic joystick



Personalised joysticks



Personalised joystick



Personalised joystick

Once all the parts have been printed, the pushbutton is assembled.

To access the video showing step by step the actions to follow in the assembly of the pushbutton, click on the following link:

https://www.youtube.com/watch?v=j_n8wtCObvQ&ab_channel=Rub%C3%A9nS%C3%A1enz

1. Check that all parts fit together and sand if necessary.

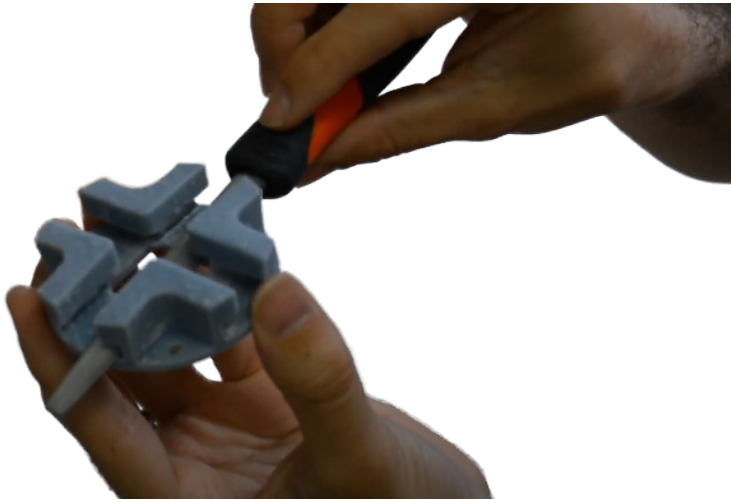

2. Stripping the wires.



3. Solder micro-switches and cable.

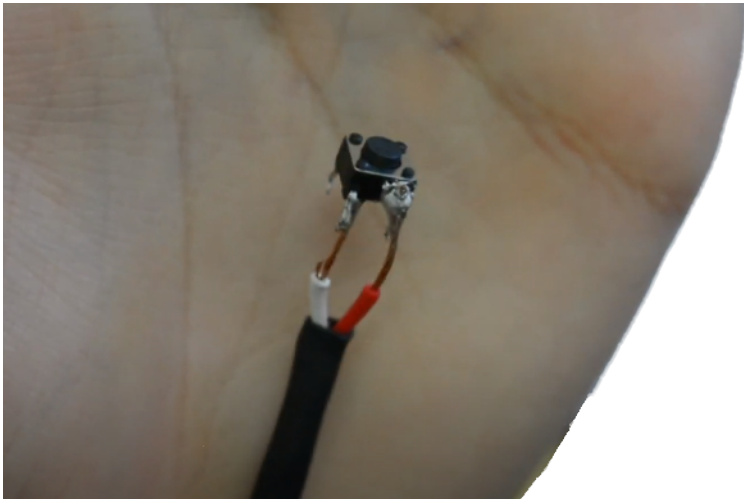

4. Solder 4 microswitches together.



5. Glue 4 micro-switches to the base.

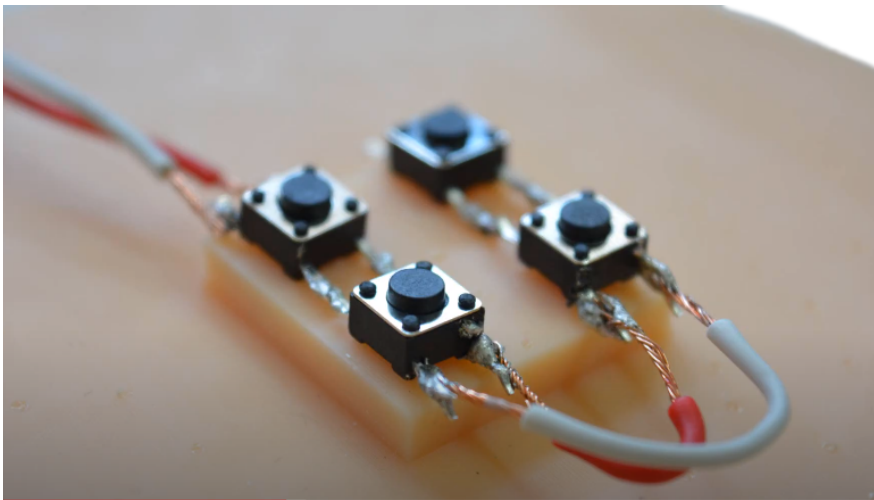

6. Passing cables through the holes.



7. Fitting micro-switches.

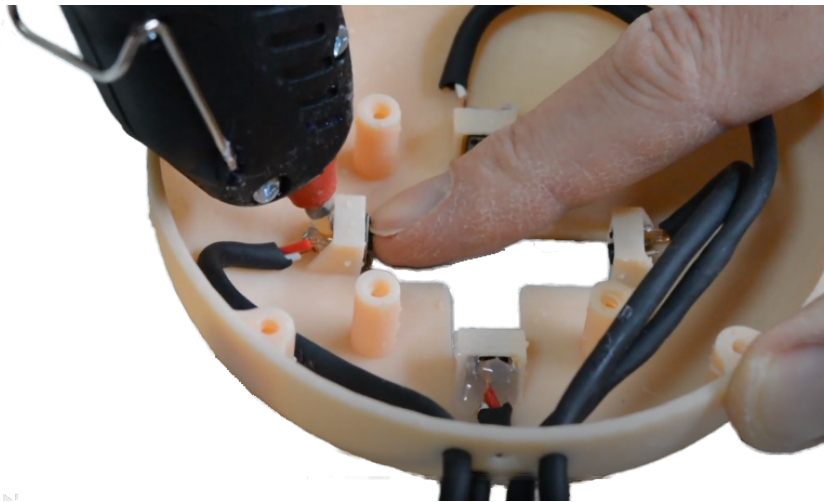

8. Gluing cables to the inside of the cover.

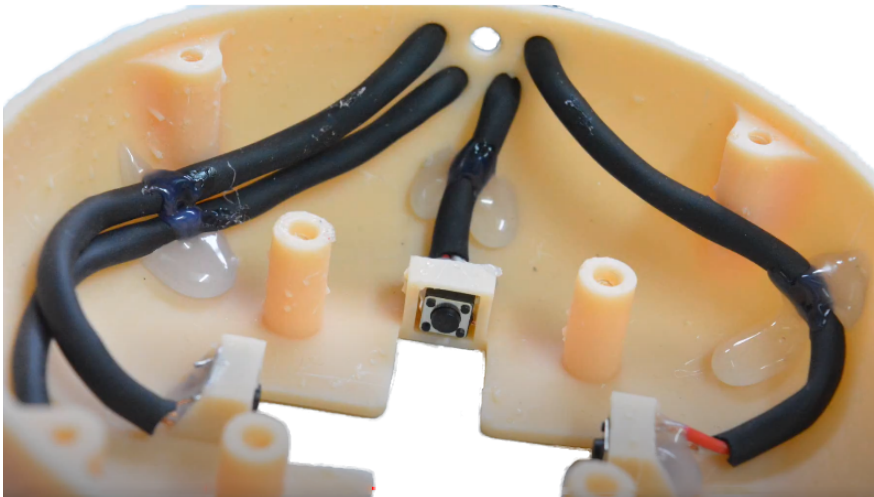

9. Coupling the guide with the cover.

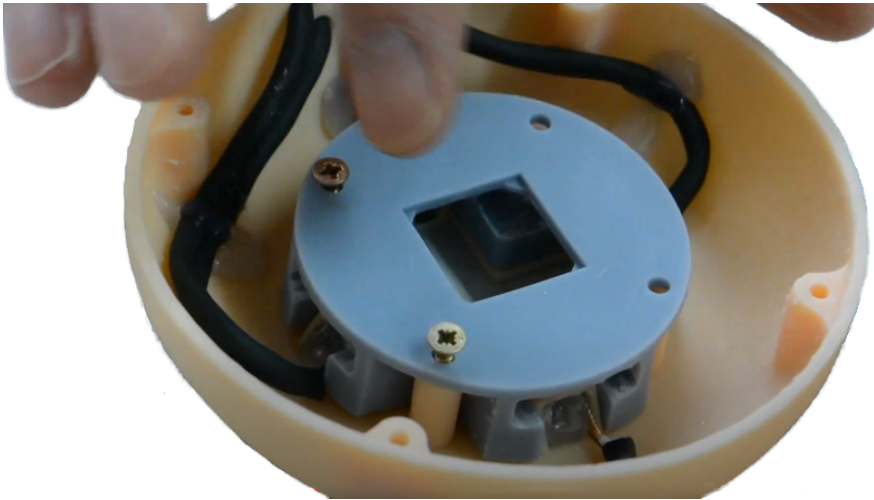

10. Place joystick.

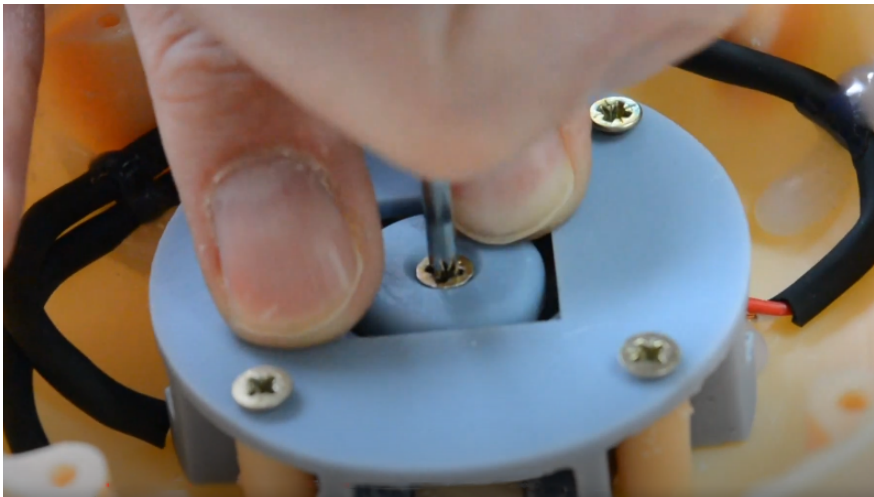

11. Pass base cable and fix with silicone.

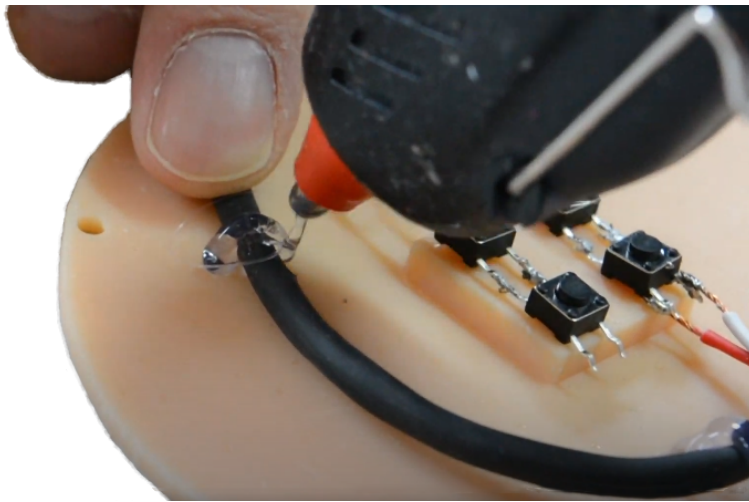

12. Place small plate and fix base.

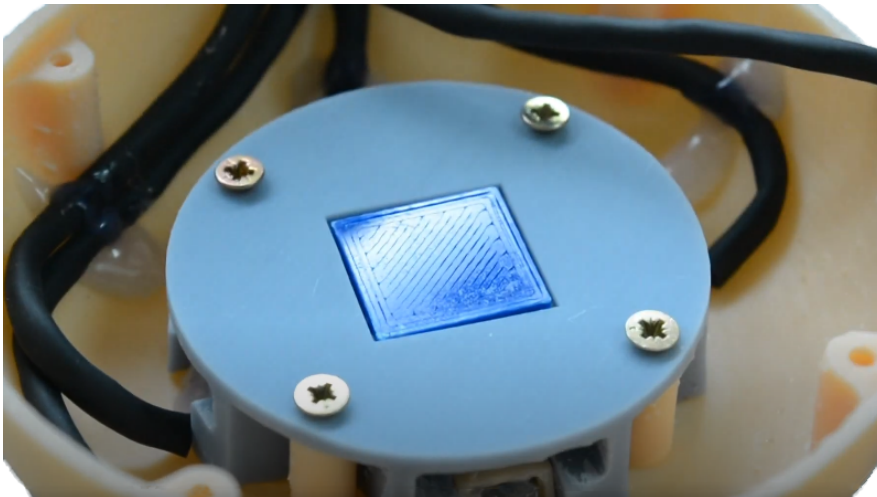

13. Solder 5 male jacks with wires.



14. Fixing cables with cable ties.



15. Gluing anti-slip adhesive rubbers.

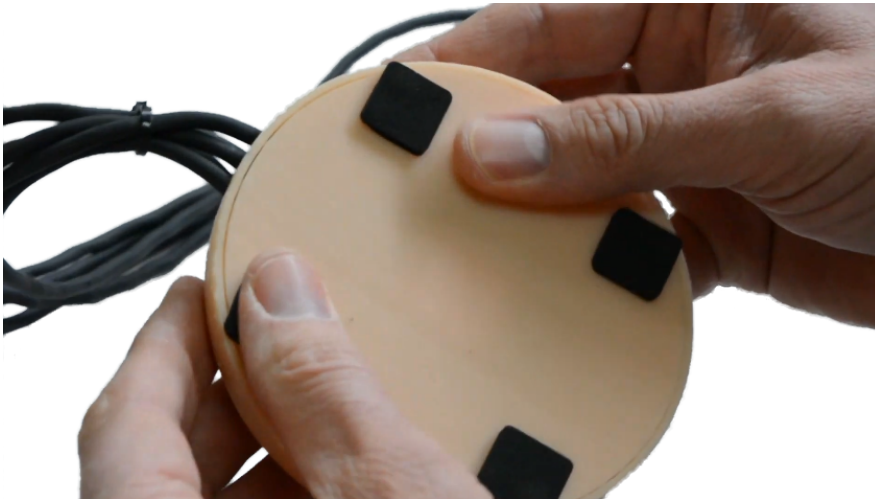

16. Connect push button.



3D PRINTER

3D PRINTER PIECES

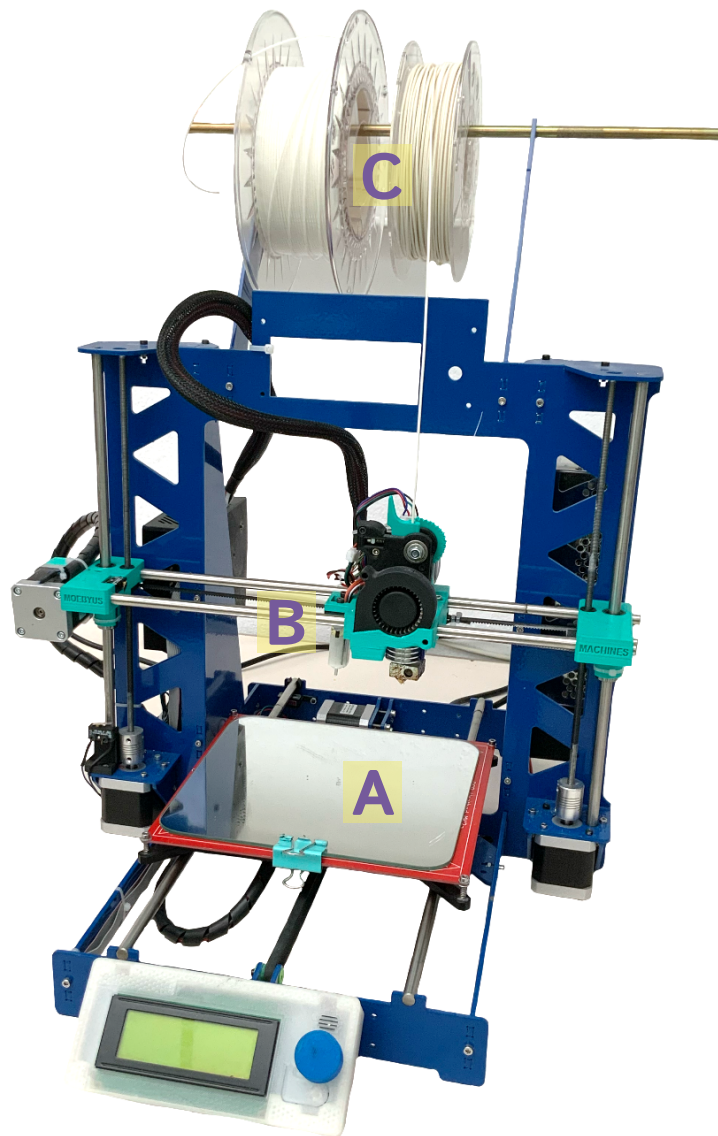

- A. **Plate or bed:** Where the first layer is glued to create an object. It is usually coated with lacquer to increase adhesion.

- B. **Extrusion head:** Through it the printer melts the filament. It has two parts: a nozzle and gears that push the filament.

- C. **Filament spool:** There is a wide range of them. In the market we can find them in different colors and sizes. The most common: PLA and ABS.

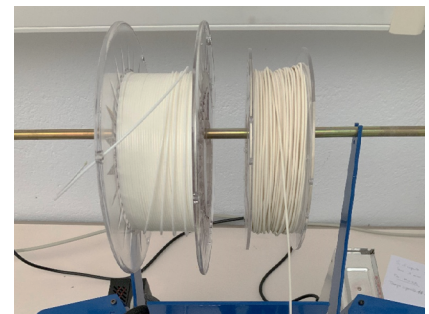
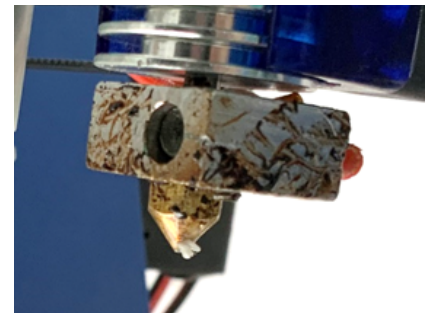
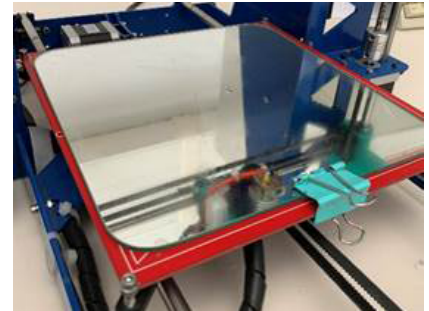

3D PRINTING MATERIALS

Before proceeding to the selection of the printing material, we must take into account from the beginning what result we expect to obtain. This is because the properties of the material will influence the printing results and the subsequent processing of the parts.

PLA: the easiest material to print with. It is used to manufacture rigid parts that degrade over time. Biodegradable.

ABS: resists high temperatures and is more durable.

PET: as strong and flexible as ABS, it has a glossy finish. It can be in contact with food and does not give off odorous fumes when melted.

PETG: suitable for food contact. Allows for better 3D printing with high transparency.



STEPS IN 3D PRINTING

1. Proposition of the idea that responds to the needs of the student.
2. Design and development of the 3D parts in CAD (Computer-Aided Design) software.
3. Once the parts are ready, we export the CAD file to an STL format (used for computer-aided design, and which defines the geometry of the 3D objects).
4. Open the STL file with a laminator program, for example, Ultimaker Cura.
5. In the program we define the printing instructions (substrates, fill density, layer height, printing speed, printing temperature, etc.).
6. Generate a G-code and save it on a storage device that recognises the printer that is going to be used, e.g. a USB stick. The G-code is a standard printing language used by many 3D printers.
7. Insert the storage device into the printer.
8. Turn on the printer and check that it is calibrated and that it has enough filament for printing.
9. Click on print

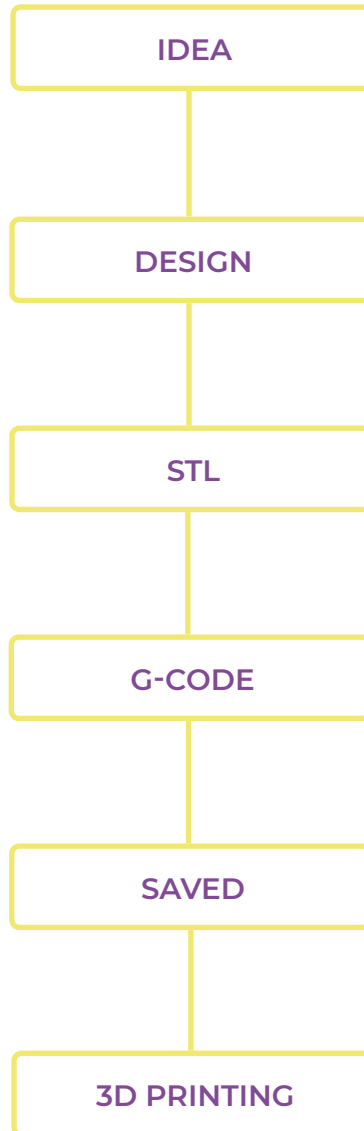



EURODDIP E

EUROPEAN DIVERSITY DESIGN FOR INCLUSIVE EDUCATION